

**ecostore**  
**2 Half Door Dual Digital Refrigerator,**  
**670lt, AISI 304 - Remote**

ITEM # \_\_\_\_\_

MODEL # \_\_\_\_\_

NAME # \_\_\_\_\_

SIS # \_\_\_\_\_

AIA # \_\_\_\_\_

**725329 (REX71FRFR)**

2-half door, dual temperature Refrigerator 670lt, -2/+10°C / -2/+10°C, digital, AISI 304, remote

**725343 (REX71FRFR)**

2-half door, dual temperature Refrigerator/Freezer 670lt, -2/+10°C / -22-15°C, digital, AISI 304, remote

### Short Form Specification

#### Item No.

Two half door refrigerator with internal and external structure in 430 AISI stainless steel; external back panel in galvanized steel and bottom panel in anti-corrosive material. Digital control with cabinet temperature display and setting and manual activation of defrost cycle. Fully compliant HACCP digital controls include visible alarms. Optimized back to front forced air flow provides even temperature distribution and fast cooling in any conditions. Fitted with 75 mm-thick cyclopentane insulating foam. Door features lock and door microswitch to switch off the fan when the door is opened. Hidden evaporator to guarantee higher storage capacity and less corrosion problems. Remote refrigeration unit; ventilated operation; internal back light; automatic defrost and evaporation of defrost water. Dual operating temperature: -2/+10°C -2/-10°C. Integrated RS485 port to facilitate connection to a remote computer and integrated HACCP systems.

### Main Features

- Right hinged two 1/2 doors.
- Large storage area suitable to contain 2/1 GN grids or shelves on anti-tilt runners.
- Optimized back to front forced air flow provide even temperature distribution and fast cooling in any conditions.
- Automatic defrost.
- Internal structure with numerous charging positions available to host grids, ensuring higher net capacity and a greater storage space.
- Cabinet fitted with up to 75 mm thickness of cyclopentane insulation for best insulating performance with 100% environmental protection (thermal conductivity: 0,020 W/m\* K).
- 60 mm-thick insulation covering the evaporator can be easily removed with a single operation.
- Rilsan coated grids for improved protection.
- Hidden evaporator thus guaranteeing higher storage capacity and less corrosion problems.
- Easy serviceability thanks to the intuitive control panel with access via app.
- Large digital white-digit display with cabinet temperature display and setting, activation of turbo frost cycle (to rapidly cool warm loads) and possibility to activate manually the defrost cycle.
- Equipped with single phase electrical cable and Schuko plug for easy and fast installation.
- Right hinged full door.
- Integrated RS485 port to facilitate connection to a remote computer and integrated HACCP systems.
- Connectivity ready for real time access to connected appliances from remote and data monitoring (requires optional accessory).
- Tropicalized unit.

### Construction

- Stainless steel runners and supports easily disassembled.
- Anti-corrosion bottom avoids any damage that may be caused to the cabinet by aggressive detergents employed to clean the floors.
- Easy access to the main components for maintenance.
- Lockable door.
- Mounted on adjustable Stainless steel feet, with castors as an option.
- Doors are self-closing and can be fully opened up to 180°.

APPROVAL: \_\_\_\_\_

- The rounded internal corners, the easily removable runners and grids allow for ease of cleaning and high hygiene standards.
- Constructed from the highest quality AISI 304 Stainless steel.

### Sustainability



- Automatic evaporation of the defrosting water by hot gas on the top for energy saving.
- Door switch stops the fan when door is opened to avoid cold air exiting the cell, thus saving energy.
- Removable triple-chamber balloon magnetic gasket to improve insulation and reduce energy consumption and ease of cleaning.
- Cleaning-free condenser: the structure of the wire frame condenser prevents dust and grease accumulation thus avoiding periodical cleaning operations and reducing energy consumption.

### Included Accessories

- 3 of 2/1GN grey rilsan grid with 2 runners PNC 881020

### Optional Accessories

- 2 stainless steel runners for refrigerated cabinets - (Marine) PNC 880242
- Set of 8 GN1/1 PVC containers for fish PNC 880243
- Spacer for 670 lt and 1430 lt refrigerated cabinets PNC 880248
- Pair of runners for GN 2/1 grids, for prostore cabinets (only for 725343) PNC 880320
- Stainless steel grid (700x530) (only for 725343) PNC 880323
- Pedal opening for cabinets PNC 880324
- Kit 4 feet, height 200mm (only for 725343) PNC 880325
- Kit of 4 feet-h=67 (marine) (only for 725343) PNC 880326
- Kit pair of runners (marine) (only for 725343) PNC 880327
- Kit remote alarm PNC 880570
- Ethernet connectivity kit IJF for Refrigeration PNC 880685
- 1/1GN plastic container with false bottom PNC 880705
- 2/1GN grey rilsan grid PNC 881004
- 2/1GN aisi 304 stainless steel grid PNC 881016
- 2/1GN 304 AISI stainless steel grid with 2 runners PNC 881018
- 2/1GN grey rilsan grid with 2 runners PNC 881020
- Set of 2 stainless steel runners for 670/1430lt refrigerators and freezers PNC 881021
- 2/1GN pvc container with lid and 2 runners PNC 881039
- 2/1GN perforated shelf PNC 881042
- 1/1GN rilsan steel wire basket h=150mm PNC 881043
- 2/1GN grey rilsan basket+2 runners h=150mm PNC 881047

Front

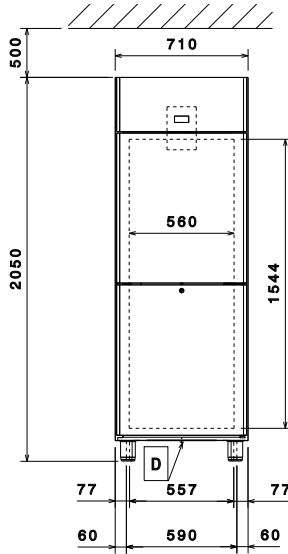

Side

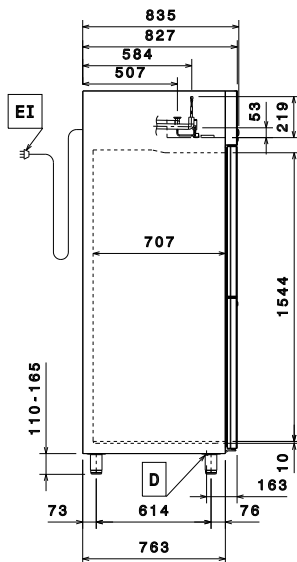

EI = Electrical inlet (power)  
 RI = Refrigerant Inlet  
 RO = Refrigerant Outlet

Top

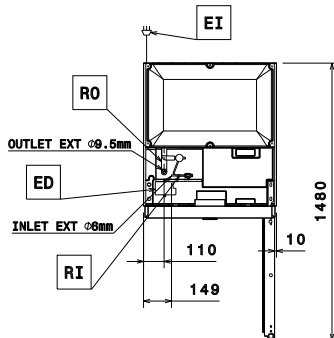

### Electric

#### Supply voltage:

725329 (REX71FRRR)	220-240 V/1 ph/50/60 Hz
725343 (REX71FRFR)	220-240 V/1 ph/50/60 Hz

#### Electrical power max.:

725329 (REX71FRRR)	0.12 kW
725343 (REX71FRFR)	0.305 kW

### Key Information:

Gross capacity:	670 lt
Door hinges:	2 Right
External dimensions, Width:	710 mm
External dimensions, Depth:	835 mm
External dimensions, Depth with Doors Open:	1480 mm
External dimensions, Height:	2050 mm
Number and type of doors:	2x1/2 Full
Number and type of grids (included):	3 - GN 2/1
Type of external material:	304 AISI
Type of internal material:	304 AISI
Internal panels material:	304 AISI
Number of positions & pitch:	40; 30 mm

### Refrigeration Data

Control type:	Digital
Refrigeration type:	
725329 (REX71FRRR)	R134a;R513A
725343 (REX71FRFR)	R404A;R452A
Suggested refrigeration power:	278 W
Suggested refrigeration power: (second unit):	
725329 (REX71FRRR)	279 W
725343 (REX71FRFR)	498 W
Condition at evaporation temperature:	-10 °C
Condition at condensation temperature:	55 °C
Condition at ambient temperature:	32 °C
Connection pipes (remote) - outlet:	9.5 mm
Connection pipes (remote) - inlet:	6 mm
*Note:	

### ISO Certificates

ISO Standards:	ISO 9001; ISO 14001; ISO 45001; ISO 50001
----------------	---

### Sustainability

#### Refrigerant type:

725329 (REX71FRRR)	R134a
725343 (REX71FRFR)	R404A